

Palletizing system

SPEED-Line

- ✓ Efficient feeding and buffering of products and components
- ✓ High plant capacity and availability
- ✓ Gentle and reliable product handling
- ✓ Maintenance-free and user-friendly
- ✓ Individual configuration due to modular design
- ✓ Robust and compact design
- ✓ Optimum accessibility due to open design
- ✓ Clean room and ESD version
- ✓ Ideal for medical, pharmaceutical, automotive, electronic and consumer good products

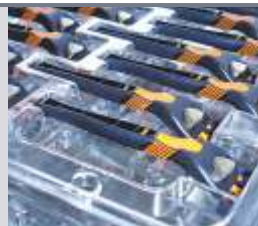
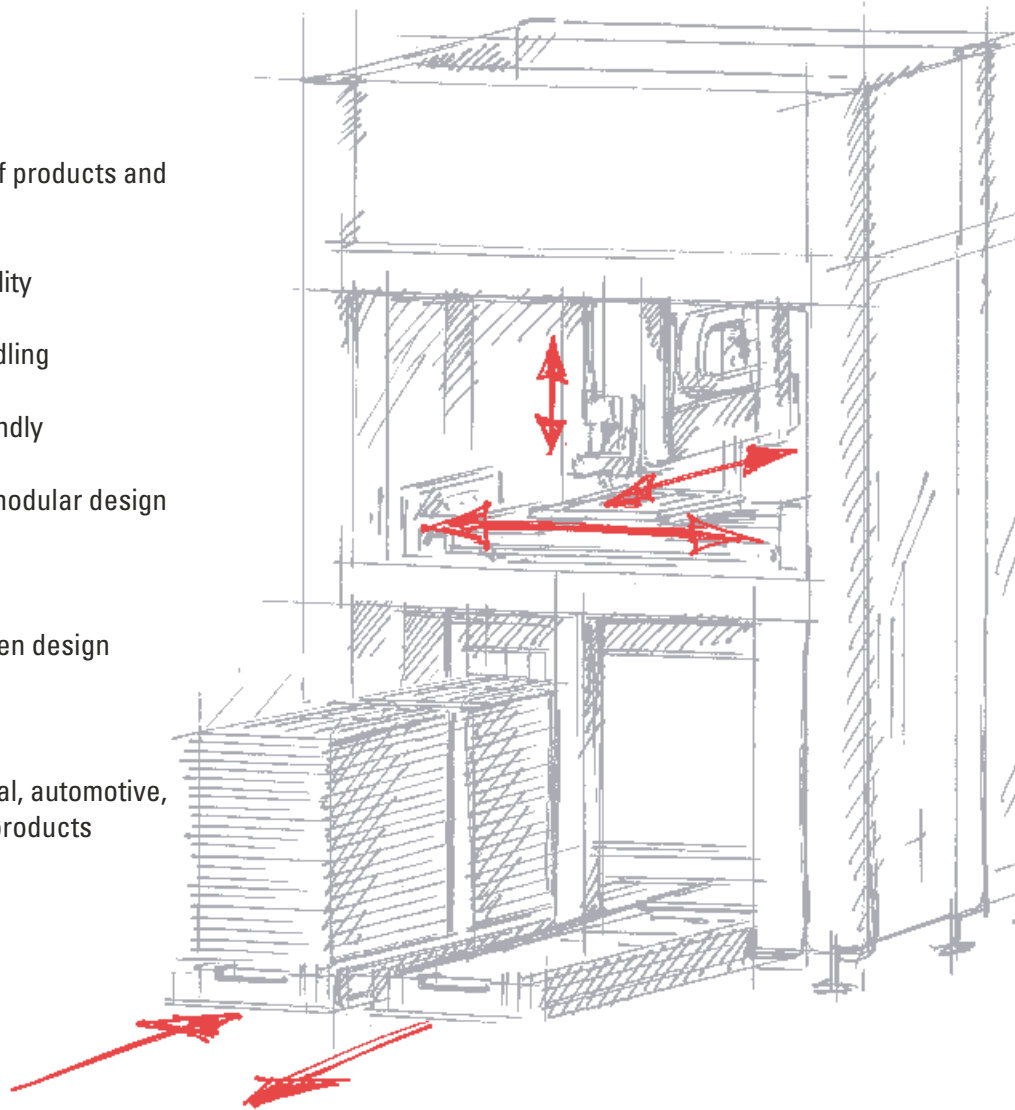

The system

The SPEED-Line palletizing system is ideal for the space-saving and efficient feeding and buffering of oriented products and modules. SPEED-Line offers all the advantages of a modern and reliable production system and ensures gentle and reliable handling, particularly of sensitive products. Design reserves and a powerful control system in conjunction with a modern user interface enable easy integration of additional handling, control and assembly tasks and make SPEED-Line an absolute all-rounder. Many years of experience in the manufacture of palletizing systems and the design of trays ensure that our customers benefit from the efficient and problem-free interaction of all components, which are specially designed to suit all logistic and product-specific requirements. Whether you are using reusable or disposable trays, deep-drawn trays of material thicknesses 0.3 – 7 mm, injection-molded trays, steel or stainless steel trays, FLG has the optimum solution for all products.



Optional modules

Hardware

- Add-on module: Protective enclosure for customer-provided transfer unit
- Assembly module: Additional assembly or handling tasks
- Trolley module: Tray feed over transport trolley, scope of delivery: 3 units
- Position sensor: Tray pile is checked to ensure it is not in the incorrect position
- Gripper quick-change system: Acceleration of change-over time for product changes
- Rotator/Expander gripper module: Adaptation to the different orientations/grids of progripper module: ducts in the tray or of customer-provided transfer unit

Software

- Diagnostic and BDE module
- Tray configurator

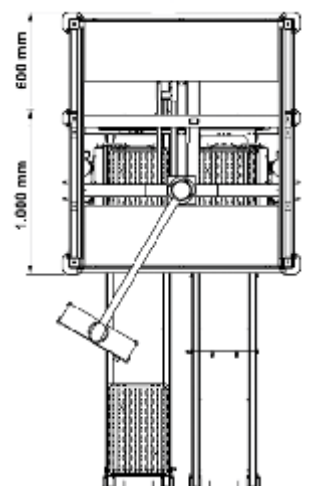
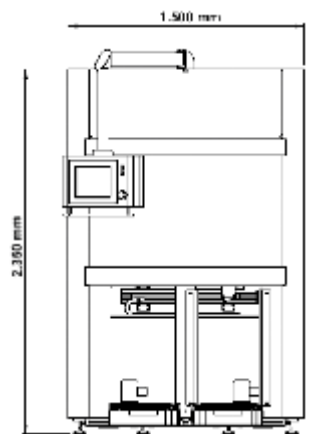

Technical data

Dimensions of basic unit (L x W x H):	1.000 x 1.500 x 2.350 mm
Tray size:	200 x 300 bis 400 x 600 mm
Tray weight:	35 kg
Tray change time (eff.):	> 2 sec
Tray stacking height:	Max. 900 mm
Plant capacity:	Max. 300 items/min
Transfer height:	800 – 1.400 mm
Drive technology:	NC axes servo-electric
Control:	PC control, Simatic S7-300, Tia-Portal
Interfaces:	MPI, Profibus, Ethernet, digital I/O

FLG Automation AG
 Max-Planck-Straße 5-7
 D-61184 Karben

Telefon: +49 6039 9240 0
 Fax: +49 6039 9240 01
 E-Mail: info@flg.de

www.flg.de